

**TENTATIVE AGENDA & MEETING NOTICE
BOARD OF COUNTY COMMISSIONERS**

**TUESDAY, OCTOBER 4, 2022
5:30 P.M.**

**WATAUGA COUNTY ADMINISTRATION BUILDING
COMMISSIONERS' BOARD ROOM**

TIME	#	TOPIC	PRESENTER	PAGE
5:30	1	CALL REGULAR MEETING TO ORDER		
	2	APPROVAL OF MINUTES: September 20, 2022, Regular Meeting September 20, 2022, Closed Session		1
	3	APPROVAL OF THE OCTOBER 4, 2022, AGENDA		9
5:35	4	APPOINTMENT OF NEW COUNTY COMMISSIONER	CHAIRMAN KENNEDY	11
5:40	5	WATAUGA COUNTY PUBLIC LIBRARY ANNUAL REPORT	MS. JANE BLACKBURN MS. MONICA CARUSO	13
5:45	6	PHASE I TRAILER STORAGE AREA IMPROVEMENTS	MR. REX BUCK	51
5:50	7	EMERGENCY SERVICES MATTERS A. Priority Dispatch License Renewal B. Rich Mountain Tower Renovation	MR. WILL HOLT	59 61
5:55	8	HOWARD'S KNOB PARK MASTER PLAN AND ACCESSIBILITY FOR PARKS GRANT APPLICATION REQUESTS	MR. ERIC SMALLWOOD MR. RON HANCOCK	65
6:00	9	MISCELLANEOUS ADMINISTRATIVE MATTERS A. Valle Crucis Elementary School Project Bid Award B. Announcements	MR. DERON GEOUQUE	71 75
6:05	10	PUBLIC COMMENT		76
7:05	11	BREAK		76
7:25	12	CLOSED SESSION Attorney/Client Matters – G. S. 143-318.11(a)(3)		76
7:45	13	ADJOURN		

AGENDA ITEM 2:

APPROVAL OF MINUTES:

September 20, 2022, Regular Meeting
September 20, 2022, Closed Session

DRAFT**MINUTES****WATAUGA COUNTY BOARD OF COMMISSIONERS
TUESDAY, SEPTEMBER 20, 2022**

The Watauga County Board of Commissioners held a regular meeting, as scheduled, on Tuesday, September 20, 2022, at 5:30 P.M. in the Commissioners' Board Room located in the Watauga County Administration Building, Boone, North Carolina.

Vice-Chairman Kennedy called the meeting to order at 5:33 P.M. The following were present:

PRESENT: Billy Kennedy, Vice-Chairman
Carrington Pertalion, Commissioner
Larry Turnbow, Commissioner
Charlie Wallin, Commissioner
Andrea Capua, County Attorney
Deron Geouque, County Manager
Anita J. Fogle, Clerk to the Board

Commissioner Wallin opened with a prayer and Commissioner Pertalion led the Pledge of Allegiance.

APPROVAL OF MINUTES

Vice-Chairman Kennedy called for additions and/or corrections to the September 6, 2022, regular meeting and closed session minutes.

Commissioner Pertalion, seconded by Commissioner Turnbow, moved to approve the September 6, 2022, regular meeting minutes as presented.

VOTE: Aye-4
Nay-0

Commissioner Pertalion, seconded by Commissioner Turnbow, moved to approve the September 6, 2022, closed session minutes as presented.

VOTE: Aye-4
Nay-0

APPROVAL OF AGENDA

Vice-Chairman Kennedy called for additions and/or corrections to the September 20, 2022, agenda.

County Manager Geouque requested that the election of new officers and the Scale House Project be added to the agenda.

Commissioner Wallin, seconded by Commissioner Peralion, moved to approve the September 20, 2022, agenda as amended.

VOTE: Aye-4
Nay-0

APPOINTMENT OF CHAIR AND VICE-CHAIR

Vice-Chairman Kennedy read Chairman Welch's letter stating his resignation from the Board of County Commissioners which was effective September 15, 2022. As Commissioner Welch was the Chairman of the Board, new officers needed to be appointed.

Commissioner Turnbow, seconded by Commissioner Wallin, moved to appoint Billy Kennedy as Chairman.

VOTE: Aye-4
Nay-0

Chairman Kennedy, seconded by Commissioner Peralion, moved to appoint Larry Turnbow as Vice-Chairman.

VOTE: Aye-4
Nay-0

PROPOSED APPALCART RURAL OPERATING ASSISTANCE PROGRAM (ROAP) GRANT APPLICATION

Mr. Craig Hughes, AppalCART Director, shared a video showcasing the various uses of transportation provided in Watauga County. After a brief update of services, including the announcement of the upcoming arrival of an electric bus, Mr. Hughes presented the Rural Operating Assistance Program (ROAP) grant application for FY 2023. Watauga County was awarded \$163,192 a decrease of \$4,375 from last year's funding. The grant does not require a local match from the County.

Vice-Chairman Turnbow, seconded by Commissioner Peralion, moved to approve the Rural Operating Assistance Program (ROAP) grant application for FY 2023.

VOTE: Aye-4
Nay-0

WATAUGA COUNTY SCHOOLS LOTTERY AND CAPITAL IMPROVEMENT PLAN (CIP) FUNDS REQUEST

Dr. Scott Elliott, School Superintendent, requested the release of \$300,000 from the State Education Lottery Fund and \$715,000 from the County's Capital Improvement Plan (CIP) reserve. The funds would be used for the following:

Lottery Project	Amount
Carpet & Tile Replacements	\$ 45,000
Replace Kitchen/Cafeteria Equipment	\$ 55,000
Gym Floors – Refinishing	\$ 20,000
Door/Window Replacements	\$ 20,000
Roof Renovations/Replacements	\$ 80,000
Pavement Resurfacing	\$ 80,000
Total	\$300,000

CIP Reserves Project	Amount
Pavement Repair/Resurface	\$ 80,000
Security Cameras	\$ 50,000
HVAC/Sewer Pumps	\$ 25,000
1:1 Devices	\$300,000
School Bus Lift Replacement	\$110,000
Mobile Unit - Hardin Park	\$150,000
Total	\$715,000

Dr. Elliott also gave a general update by sharing that there was a smooth start to the new school year of which enrollment was up to 4,766 this year from 4,530 last year. The school system has hired 86 new employees with 54 of those being new teachers. All schools within the County met or exceeded their growth schedule. Mental Health services were being increased within the school system and a potential grant may allow for an additional School Resource Officer (SRO). Dr. Elliott thanked the Board for the current SRO positions and commended Captain Preston Russell and Mr. Will Holt, Emergency Services Director, on their help with the issue involving the vehicle carrying explosive material that wrecked on the second day of the school year near Watauga High School.

Commissioner Wallin, seconded by Vice-Chairman Turnbow, moved to release the funds as requested.

VOTE: Aye-4
Nay-0

MONTHLY COLLECTIONS REPORT

County Manager Geouque, on behalf of Mr. Larry Warren, Tax Administrator, presented the Monthly Collections Report. There were no releases in August 2022. The report was for information only; therefore, no action was required.

HOWARD’S KNOB GRANT UPDATE

County Manager Geouque introduced Mr. Eric Smallwood, the County’s new Parks and Recreation Director. The Board welcomed Mr. Smallwood who then gave an update to the Board on the Howard’s Knob Grant. Mr. Smallwood stated that he was working with the Watauga County Tourism Development Authority (TDA) and Destination By Design on renovations at

Howard's Knob Park. The TDA would provide the 20% match needed for the grant. Mr. Smallwood also stated that the Recreation Commission would hold a public meeting on September 28, 2022, to inform the public of the project. The report was for information only; therefore, no action was required.

MISCELLANEOUS ADMINISTRATIVE MATTERS

A. Scale House Project

County Manager Geouque stated that the Scale House Project has been broken into smaller projects, some of which would be self-performed to keep costs down. To keep the project moving forward, a price quote was presented from Charlotte Scale Co., Inc. for the scales, including installation. The quote totaled \$219,910.

Vice-Chairman Turnbow, seconded by Commissioner Pertalion, moved to approve the purchase of the items needed to install the scales for the Scale House Project from Charlotte Scale Co., Inc. as presented by the County Manager.

VOTE: Aye-4
Nay-0

B. Armory Planning Committee

County Manager Geouque stated that the first meeting of the Armory Planning Committee would be on October 3, 2022, at 2:00 P.M. After the meeting, a tour of the facility would be conducted. Chairman Kennedy stated that, even though he is not on the committee, he would like to attend the meeting to observe and then join the tour of the facility. The County Manager stated that the County did need space in the facility for recreation equipment.

Vice-Chairman Turnbow and Commissioner Pertalion are members of the Armory Planning Committee. An additional appointment was needed; however, such appointment was tabled to a future meeting.

C. Request to Extend the Current Forest Service Lease

County Manager Geouque stated that the Forest Service requested an extension on their lease to use office space at the cooperative extension building. The lease was set to expire on September 30, 2022. The Forest Service requested to extend the lease through June 30, 2023. All terms and conditions would remain the same.

Board approval, contingent upon County Attorney review, would be required to approve the lease and completion of PO-28 Lease proposal form after the adoption and publication of the proposed resolution.

Commissioner Wallin, seconded by Vice-Chairman Turnbow, moved to adopt the resolution as presented.

VOTE: Aye-4
Nay-0

D. Boards and Commissions

County Manager Geouque presented the following for consideration:

Watauga County Nursing Home Community Advisory Committee

Regional Ombudsman, Ms. Stevie John, requested Ms. Barbara Hunsucker and Ms. Patricia Coley be considered for reappointment to serve on the Watauga County Nursing Home Community Advisory Committee for three-year terms each. These were first readings.

Vice-Chairman Turnbow, seconded by Commissioner Pertalion, moved to waive the second reading and reappoint Ms. Barbara Hunsucker and Ms. Patricia Coley each to three-year terms on the Watauga County Nursing Home Community Advisory Committee.

VOTE: Aye-4
Nay-0

E. Announcements

County Manager Geouque announced the following:

- Upon the future completion of the new National Guard facility in Morganton, the facility located on Hunting Hills Lane will be under the joint ownership of Watauga County and the Town of Boone. A Committee has been seated to help develop the future uses of the facility. The kick-off meeting for the Committee will be held on October 3, 2022, from 2:00 P.M. until 5:00 P.M. The informational meeting will be held at the Community Recreation Center with a walk-through of the Armory to follow.
- Please save the date of October 6, 2022, at 2:00 P.M. for a meeting with the Board of Commissioners as well as BREMCO and Skyline representatives to view the progress to expand critical broadband service availability to the majority of homes in the County. The location is yet to be determined.
- AppalCART will be unveiling their first battery electric bus on Wednesday, September 28, 2022, at 6:00 P.M. at 283 Martin Luther King, Jr. Street.

PUBLIC COMMENT

There was no public comment.

CLOSED SESSION

At 6:22 P.M., Commissioner Wallin, seconded by Commissioner Pertalion, moved to enter Closed Session to discuss Attorney/Client Matters, per G. S. 143-318.11(a)(3).

VOTE: Aye-4
Nay-0

Commissioner Pertalion, seconded by Commissioner Wallin, moved to resume the open meeting at 7:56 P.M.

VOTE: Aye-4
Nay-0

POSSIBLE ACTION AFTER CLOSED SESSION

Chairman Kennedy stated that with the resignation of Chairman Welch, and in accordance with North Carolina General Statute 153.A-27, the Board of County Commissioners shall consult the County Democratic Executive Committee before filling Commissioner Welch's vacancy. The Board plans to have a nominee for appointment at one of the Board meetings in October.

Chairman Kennedy stated that the Board of Commissioners conducted an evaluation of the County Manager, Mr. Deron Geouque. Mr. Geouque accepted the terms of a new employment contract effective immediately and lasting until December 2027 at which time it would automatically renew on a year by year basis.

Commissioner Pertalion, seconded by Commissioner Wallin, moved to approve the employment contract with the County Manager, Mr. Deron Geouque.

VOTE: Aye-4
Nay-0

ADJOURN

Commissioner Pertalion, seconded by Commissioner Wallin, moved to adjourn the meeting at 7:58 P.M.

VOTE: Aye-4
Nay-0

Billy Kennedy, Chairman

ATTEST:
Anita J. Fogle, Clerk to the Board

Blank Page

AGENDA ITEM 3:

APPROVAL OF THE OCTOBER 4, 2022, AGENDA

Blank Page

AGENDA ITEM 4:

APPOINTMENT OF NEW COUNTY COMMISSIONER

MANAGER'S COMMENTS:

Chairman Kennedy will discuss filling the vacancy by the resignation of Commissioner Welch. Staff understands per North Carolina General Statute 153A-27 that consultation with the Watauga Democratic executive committee has been completed. A name will be put forth and upon approval of the Board of Commissioners will be sworn in to fill former Commissioner Welch's seat.

Blank Page

AGENDA ITEM 5:

WATAUGA COUNTY PUBLIC LIBRARY ANNUAL REPORT

MANAGER'S COMMENTS:

Ms. Jane Blackburn, Director of Libraries, Appalachian Regional Library, will present the Watauga County Public Library Annual Report.

The report is for information only; therefore, no action is required.

APPALACHIAN REGIONAL LIBRARY 2021-2022

Ashe, Wilkes, and
Watauga Counties

ARL'S FIVE YEAR PLAN

2022-2026

LIVE A LARGER LIFE @ARL

Our New Mission Statement

ARL's mission is to nurture individual and community growth through free and equal access to resources for reading, thinking, learning, and living.

4 REGIONAL GOALS

- Become Known as the Gateway to and Centerpiece of our Communities
- Create Innovative Programming, Outreach, and Partnerships
- Deliver Robust Technology and Digital Literacy Programming
- Build High Quality Collections

WILKES COUNTY PUBLIC LIBRARY'S GOALS

- Community Collaborations and Partnerships
- Innovative and Relevant Services and Programming
- Technology and Digital Literacy
- Maintain and Expand Collections
- Organizational Excellence

WATAUGA COUNTY PUBLIC LIBRARY'S GOALS

- Organizational Excellence
- Robust Services to Underserved Communities
- Increased Access and Innovative Programming
- Expansive Print and Digital Collection

ASHE COUNTY PUBLIC LIBRARY'S GOALS

- Bring Library Services to Diverse Populations Throughout the County
- Foster a Lifelong Love of Reading for All Ages and All Levels of Literacy
- Provide Programs that Inspire Learning, Imagination, and Growth
- Welcome the Community into a Friendly and Well-Maintained Library
- Serve as a Technology Hub for the Community

2021-2022 STATISTICS

USERS OF OUR LIBRARIES AND SERVICES: #S QUICKLY REBOUNDED

21-22

Cardholders	94,197
▪ Adults	52,493
▪ Children	41,254
Visitors	225,446
Programs	974
Program Attendees	31,586
Computer Users	18,866
WiFi Users	235,211
Circulation	474,524

20-21

Cardholders	87,438
Adults	50,726
Children	36,712
Visitors	172,303
Programs	624
Program Attendees	22,191
Computer Users	9,751
WiFi Users	139,800
Circulation	436,873

19-20

Cardholders	84,281
▪ Adults	49,251
▪ Children	35,030
Visitors	285,567
Programs	2,073
Program Attendees	43,703
Computer Users	36,179
WiFi Users	32,653
Circulation	445,339

PROGRAMS AND SERVICES

- Chat and Telephone Reference
- Free online magazines
- Curbside Service
- Facebook Programs
- Youtube Programs
- Live programs presented at outside sites
- Take and Make kits available to children, teens, and adults
- Increased #s of books available through NCKids Digital
- Tumblebooks available for free to patrons at home

PROGRAMS AND SERVICES

- Hotspots to check out
- Lenovo laptops available for checkout
- COVID-19 tests to give away to public
- Ancestry.Lib is still available remotely for our patrons
- Touchless Library Cards
- Remote computer assistance in-house
- Hybrid meetings and programming with the OWL
- Virtual programming via Zoom

GRANTS for special projects/programs

LSTA Adapting Technology	\$40,000	(region)
LSTA SLNC Adapts	\$25,000	(region)
LSTA Bright Ideas	\$15,000	(region)
VITA	\$11,500	(Watauga)
ALA ARP Humanities	\$10,000	(Ashe)
South Arts	\$10,000	(Ashe)
Emergency Connectivity Funds	\$9,110	(region)
LSTA Literacy @ the Laundromat	\$3,500	(Wilkes)
LSTA Staff Scholarships	\$5,500	(3 staff)
Blue Ridge Energy	\$3,000	(Watauga)
Leap into Science	\$1,000	(Watauga)

GRAND TOTAL \$133,610

(vs \$97,031 in 20-21)

OUR LIBRARIES

and their proudest
moments

WILKES COUNTY PUBLIC LIBRARY PROGRAMMING AND PARTNERSHIPS

NEW programs, outreach, and partnerships were developed for children, teens, and families

Traphill attracts visitors with NEW programs and resources

Grants from North Carolina Humanities Council and State Library LSTA funds enhance programming and resources

NEW PROGRAMS, OUTREACH, AND PARTNERSHIPS WERE DEVELOPED FOR CHILDREN, TEENS, AND FAMILIES



TRAPHILL ATTRACTS VISITORS WITH NEW PROGRAMS AND RESOURCES



GRANTS ENHANCE PROGRAMMING AND RESOURCES



JUNE 2022
DRIVING WITH THE DEVIL

Reading schedule:
 June 1-5...pages 1-100
 June 6-12...pages 101-193
 June 13-19...pages 194-294
 June 20-26...pages 295-366



"Thompson examines the sport's Prohibition-era roots in this colorful, meticulously detailed history." — TIME

Southern Moonshine, Detroit Wheels, and the Birth of NASCAR

Driving WITH THE DEVIL



June 23 at 7:00 PM | NASCAR HOF, Charlotte



North Carolina humanities 50 years

in memory of the UNION



ASHE COUNTY PUBLIC LIBRARY

The return of in-library events

Grant funding expands library services

Keeping our collections current

THE RETURN OF IN-LIBRARY EVENTS

THE RETURN OF IN-PERSON LIBRARY EVENTS



GRANT FUNDING EXPANDS LIBRARY SERVICES

GRANT FUNDING EXPANDS LIBRARY SERVICES

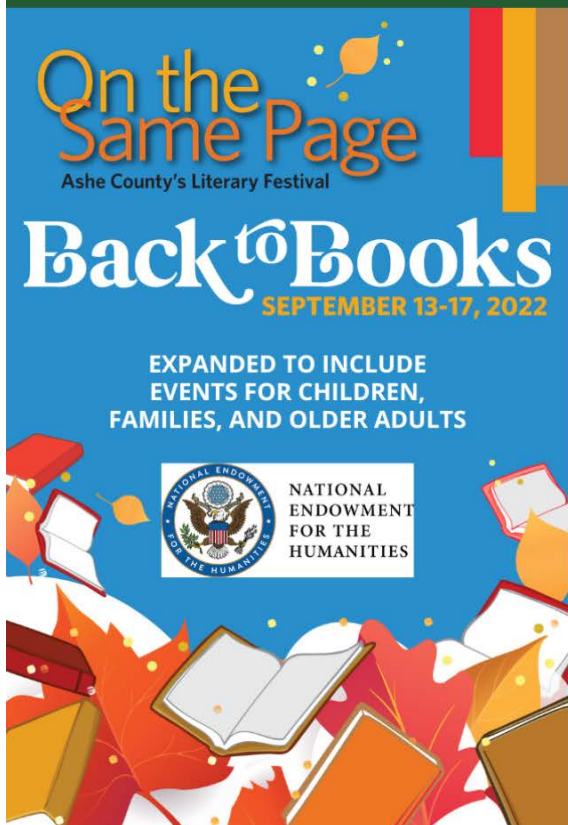

WATAUGA COUNTY PUBLIC LIBRARY

Celebrated the Library building's 25th anniversary in April during National Library Week

Partnered with the Town of Boone for the Boone 150 celebration with local author talks all year

Began preliminary work toward expansion of the building

25TH ANNIVERSARY IN THE CURRENT BUILDING



Join Us!
**25th Anniversary Celebration
of the Library's Home**
Wednesday, April 6th, 11:30 am - 2:30 pm

Cupcakes, Slide Show & Music
Twist the balloon man
View our commemorative brick wall patio
Learn about our new Five -Year Plan

The poster features a central photograph of a brick building with a red roof and a circular window, set against a green lawn and trees. The background is light blue with falling gold streamers. Two clusters of three balloons (purple, blue, and yellow) are positioned on either side of the main text.

PARTNERSHIP WITH BOONE 150

FIRST FRIDAY IN JUNE!
APPALACHIAN HERITAGE DAY

3RD JUNE, 2022
 5:30-6:30 ON LIBRARY LAWN

APPLE CIDER PRESSING
APPLE STACK CAKE SAMPLES
TAKE N' BAKES
CORN HUSK DOLLS
APPLE HEAD DOLLS
WHIRLI-GIGS
MUSIC BY PICKIN' THISTLES

Make sure you go check out the Blue Ridge Fiber Guild exhibit opening at the Jones House, 5-8pm!

Celebrate Appalachian heritage with us at the Watauga County Public Library as part of Boone's 150th celebrations!

BOONE 150 NORTH CAROLINA • 1872-2022
www.Boone150.com

Watauga County Public Library
Appalachian 1872-2022

BOONE READS TOGETHER

Author Talk with Dr. Eric Plaag

REMEMBERING BOONE
 150th Anniversary Edition

How did Boone grow from a tiny county seat into the bustling hub of commerce, higher education, and mountain tourism we know today? Find out through this curated collection of historical photos and accompanying narrative.

Thursday, March 12th, at 6pm in the Watauga County Public Library.

To attend in-person, RSVP here, or call 828-264-8784 ext 2:

Want to attend virtually? Go to the library's Facebook page at the time of the event!

BOONE 150 NORTH CAROLINA • 1872-2022
 Copies of the book are available at the library!

Boone Before Boone
 The Archaeological Record of Northwestern North Carolina Through 1769

THOMAS R. WHYTE

49 Contributions to Southern Appalachian Studies

MAKING PLANS TO EXPAND

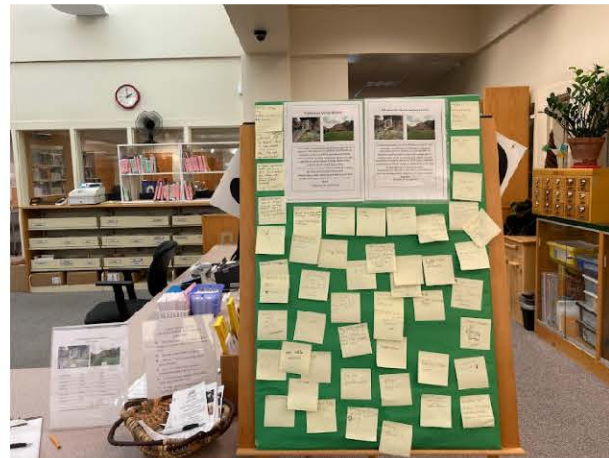

\$ \$ \$ \$ \$ \$ \$ \$ \$ \$ \$ \$

2021-2022 Budget

ARL TOTAL REVENUES FOR 2021-22 \$2,672,271

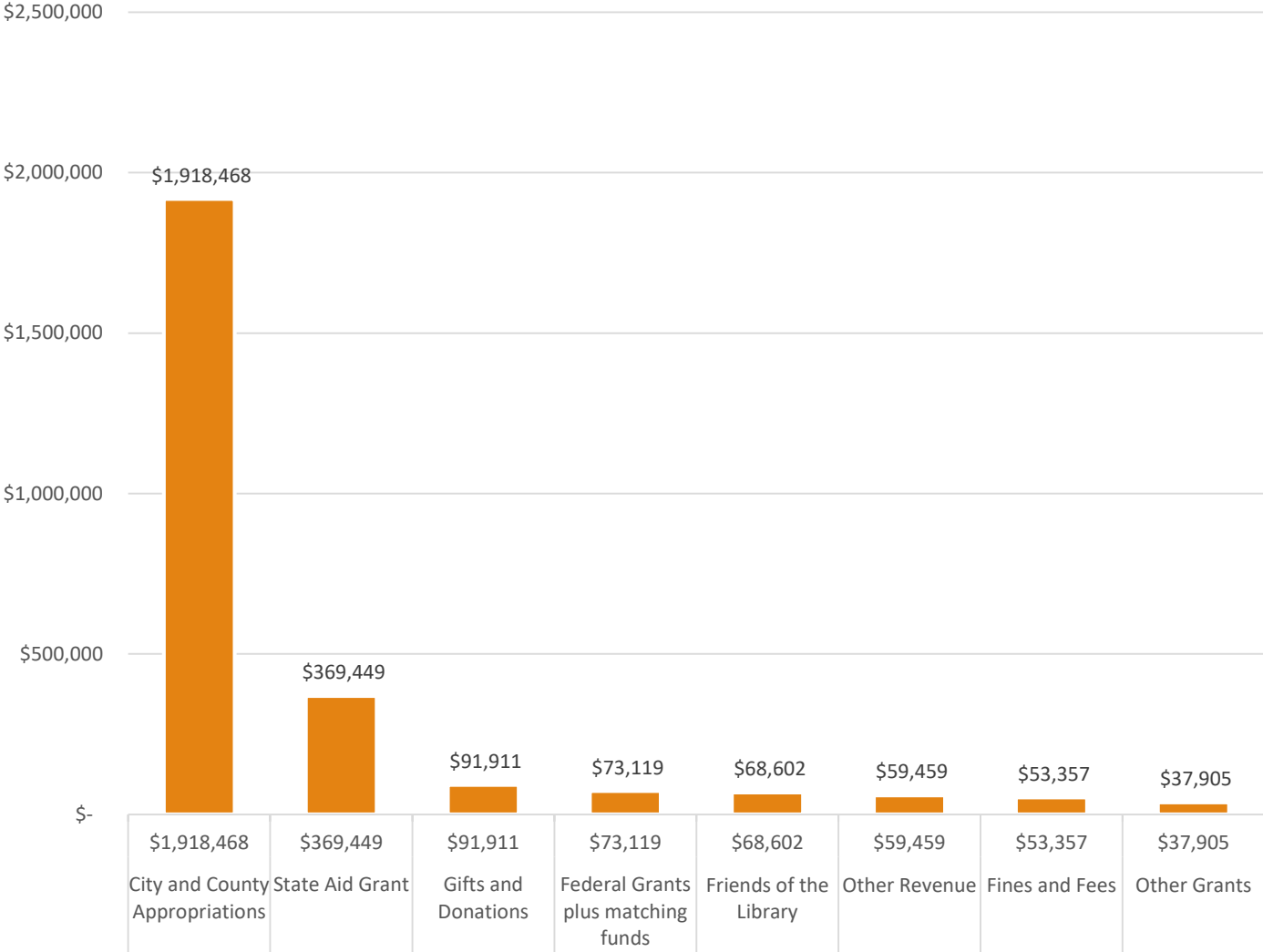

ARL EXPENDITURES FOR 2021-22 \$2,666,308

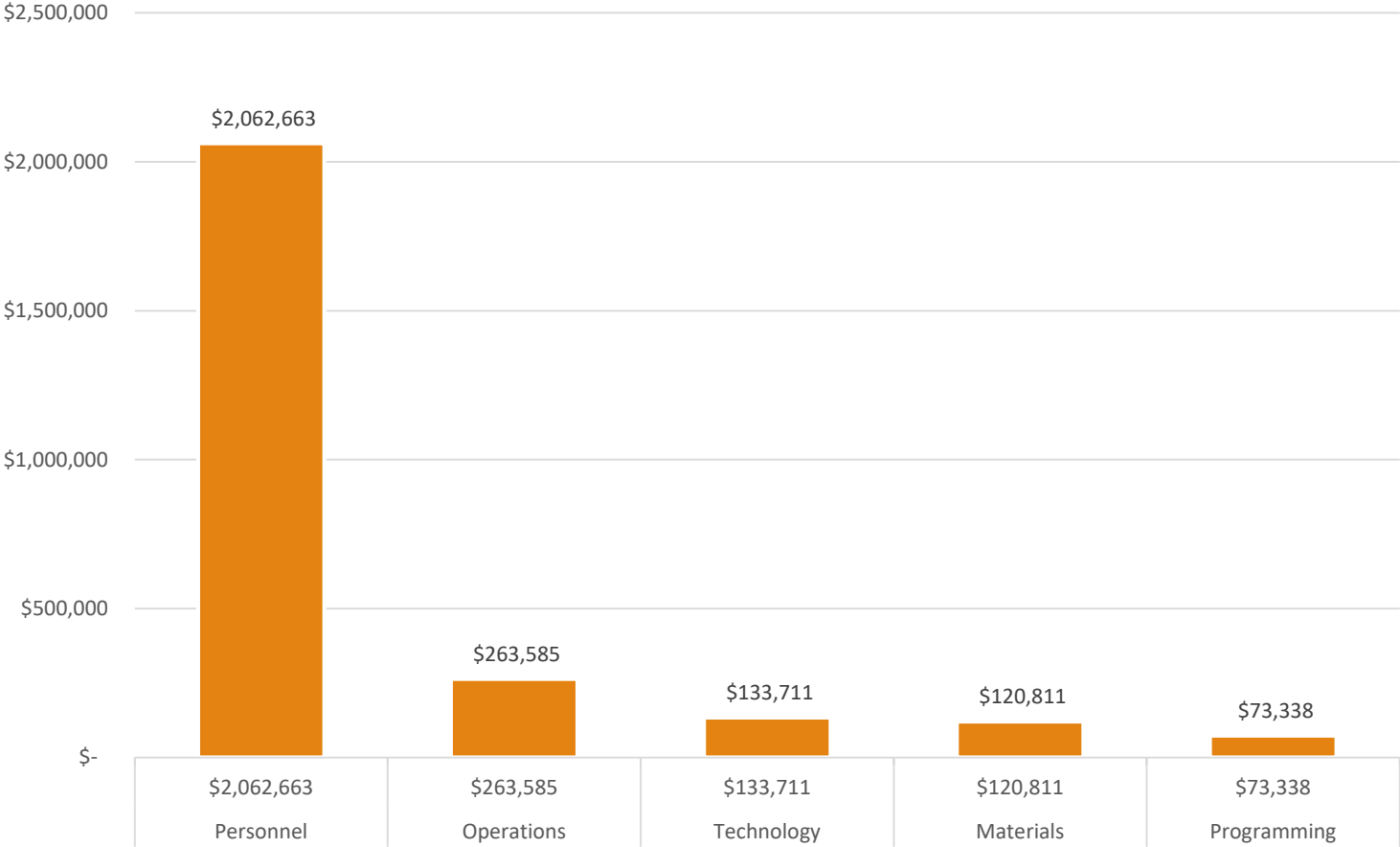

ASHE REVENUES FOR 2021-22 \$574,920



ASHE EXPENDITURES FOR 2021-22 \$583,484

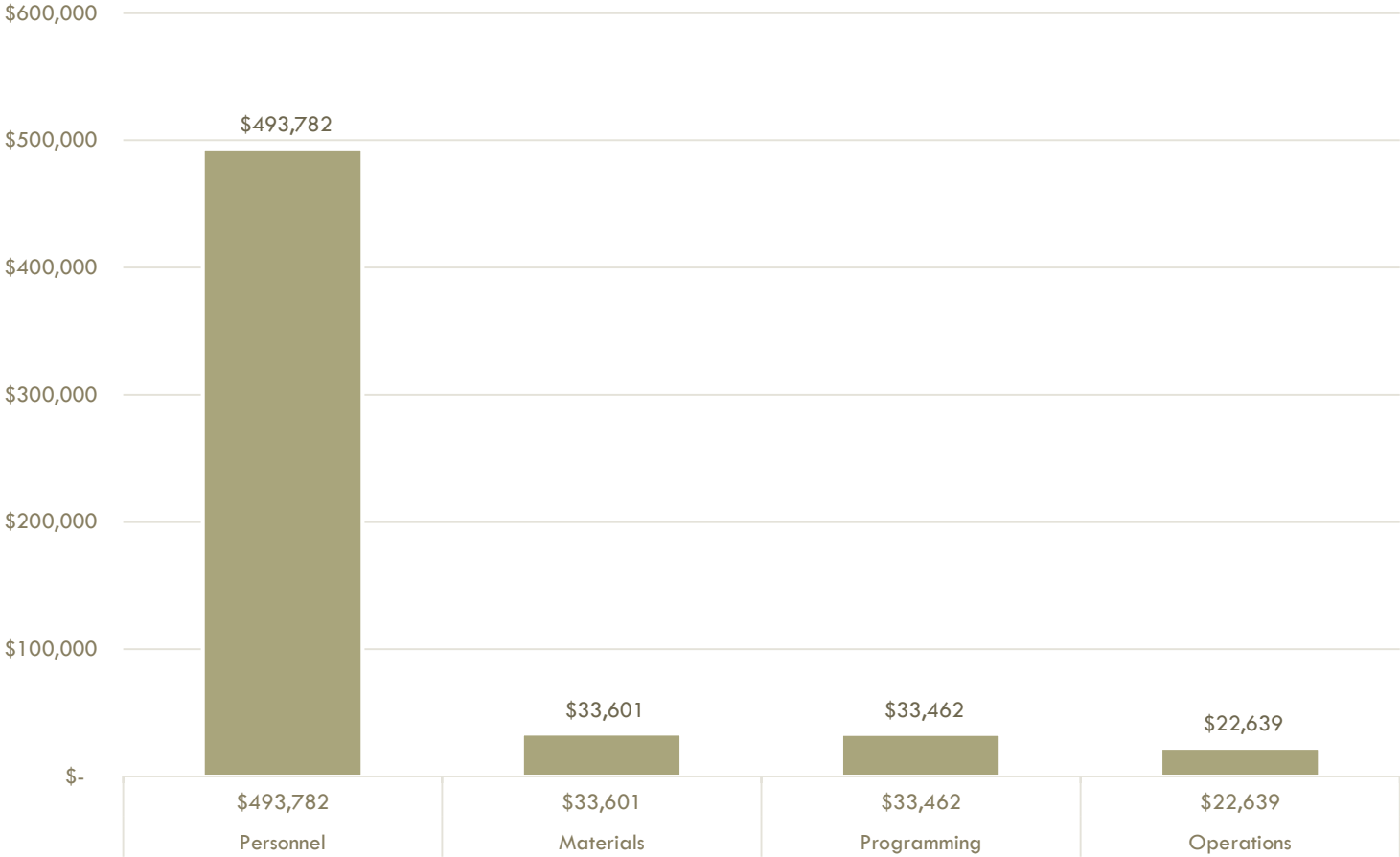

WATAUGA REVENUES FOR 2021-22 \$807,218

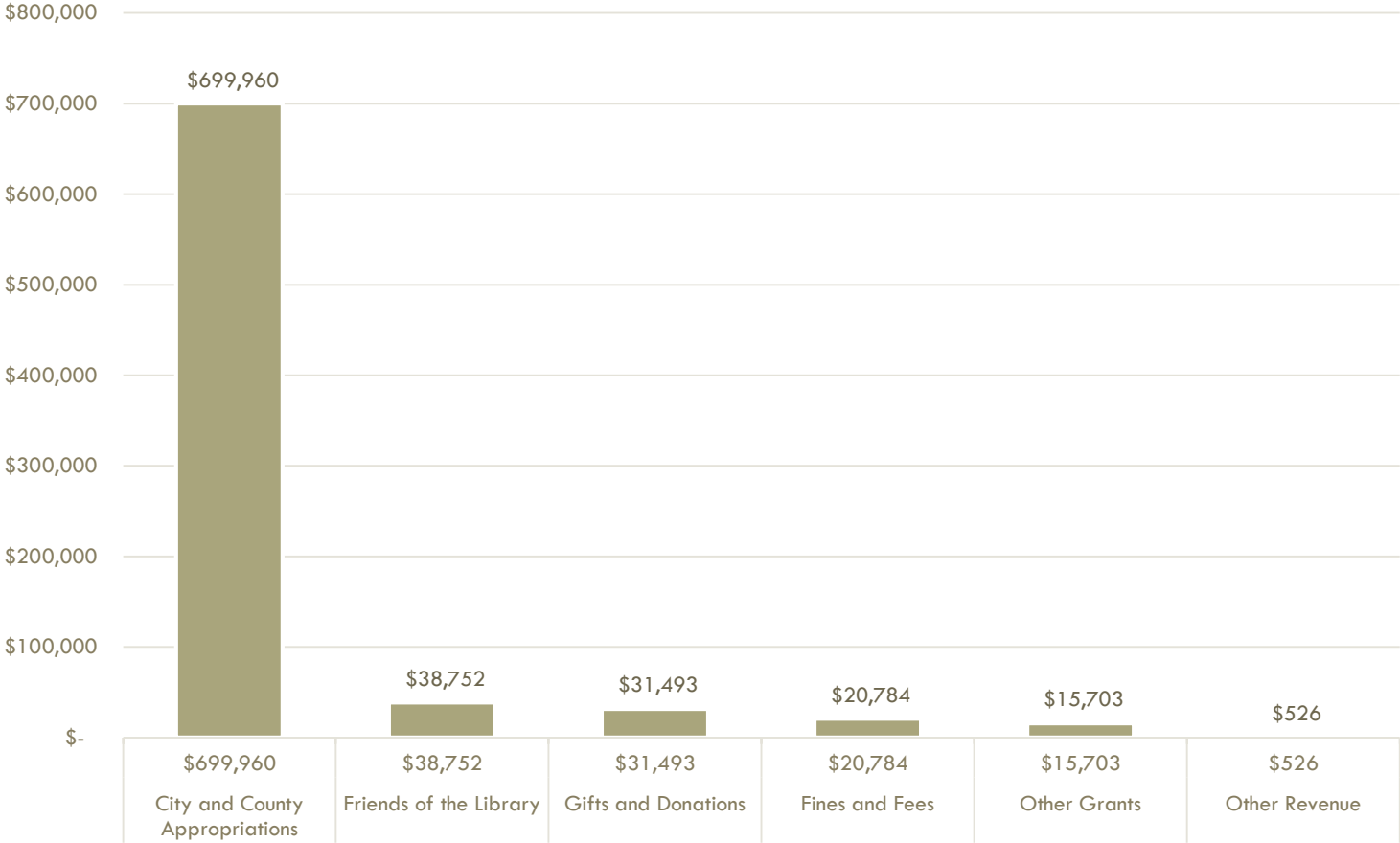

WATAUGA EXPENDITURES FOR 2021-22 \$808,078

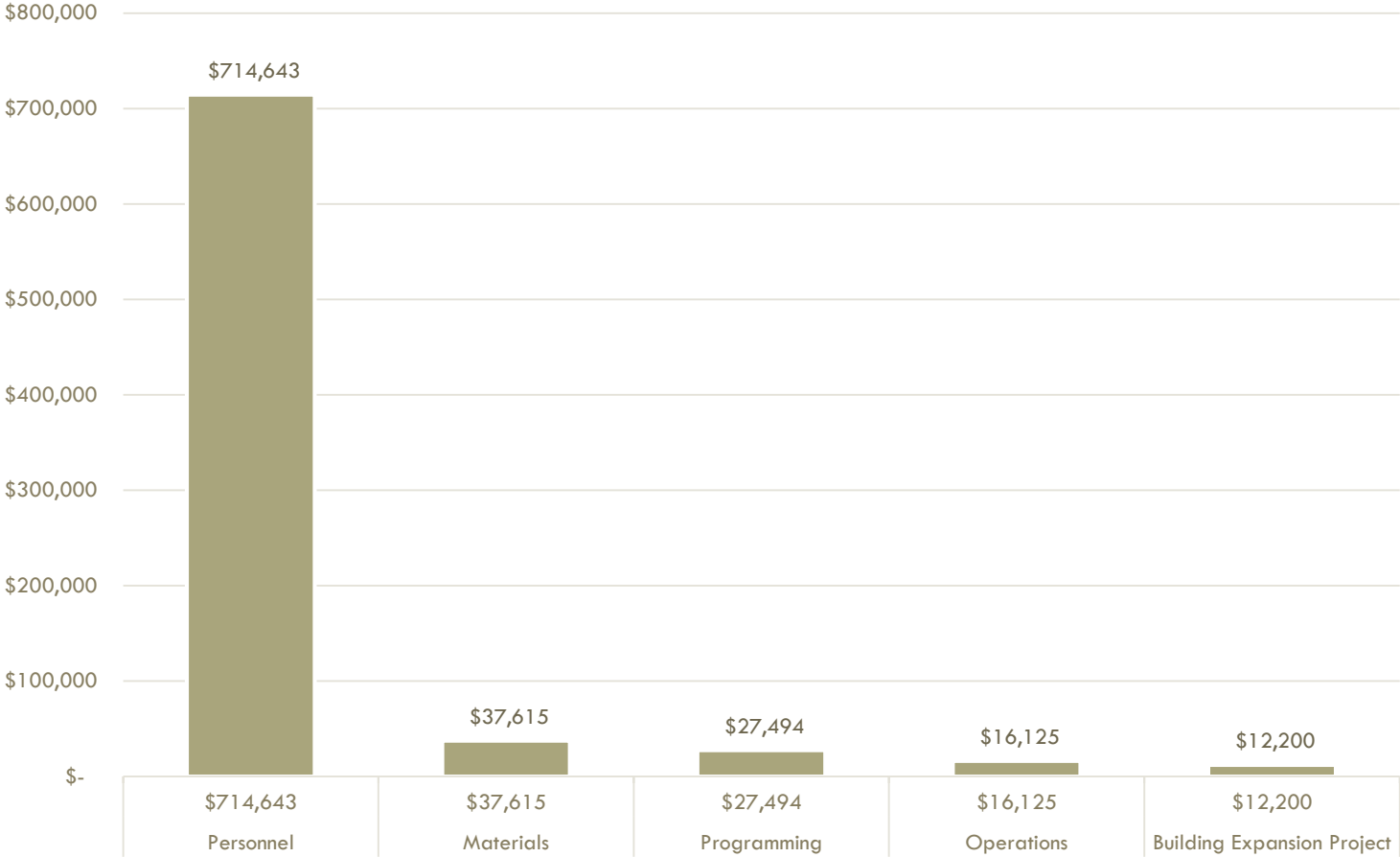

WILKES REVENUES FOR 2021-22 \$800,285



WILKES EXPENDITURES FOR 2021-22 \$764,010

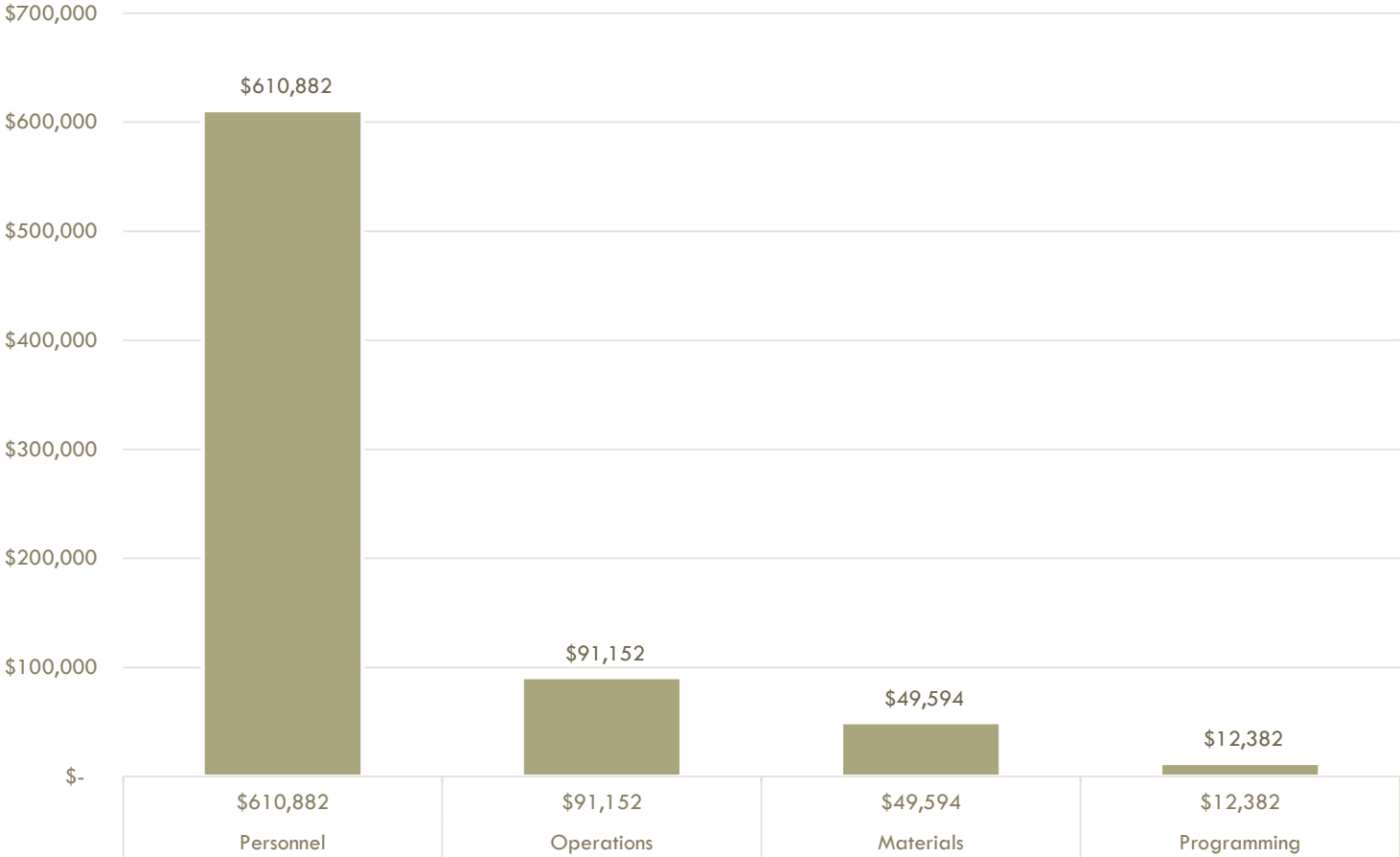

LOOKING FORWARD

2022-2023

2022-2023

- **Hiring a new regional director**
- **Year 2 of our 5 Year Plan:
LOTS to implement!**
- **Working on finding money for the renovation & expansion at the Watauga County Public Library**



Visit our website at

www.arlibrary.org

AGENDA ITEM 6:**PHASE I TRAILER STORAGE AREA IMPROVEMENTS****MANAGER'S COMMENTS:**

Staff solicited quotes for Phase I of the Trailer Storage Area Improvements project. A total of three (3) quotes were received with the following results:

- PADCO Excavating, Inc - \$119,569.16
- Carolina Grading and Utilities, Inc. - \$148,500.00
- JW Hampton Company - \$192,000.00

In addition, staff requests authorization to purchase from PADCO Excavating, Inc. in the amount of \$69,220.80 storm grate inlet, concrete junction box, and stormwater manhole structures.

Staff requests Board approval to contract with PADCO Excavating, Inc. for earthworks in the amount of \$119,569.16 and the purchase of supplies and materials in the amount of \$69,220.80 for a total amount of \$188,789.96 for the Phase I Trailer Storage Area Improvements



WATAUGA COUNTY

*SANITATION
DEPARTMENT*

336 Landfill Road – Boone, NC 28607 – (828) 264-5305
TDD 1-800-735-2962 – Voice 1-800-735-8262 – FAX (828) 264-3230

September 28, 2022

To: Deron Geouque, County Manager

From: Rex Buck, Operations Services Director

Subject: Trailer Storage Area Improvements

Staff solicited quotes for Phase I of the Trailer Storage Area Improvements project. A total of three (3) quotes were received with the following results:

- PADCO Excavating, Inc - **\$119,569.16**
- Carolina Grading and Utilities, Inc. - \$148,500.00
- JW Hampton Company - \$192,000.00

Staff requests authorization to contract with PADCO Excavating, Inc. in the amount of **\$119,569.16** for Phase I of the Trailer Storage Area Improvements project.

Staff, also, requests authorization to purchase and have PADCO Excavating, Inc. install Storm Grate Inlet, Concrete Junction Box, and Stormwater Manhole structures for the Trailer Storage Area project at a cost of - **\$69,220.80**. These items were not included in the scope of service initially quoted for the Grading and Earthworks phase of the project.

Total cost for Phase I of the Trailer Storage Area Improvements project is - **\$188,789.96**.

PADCO Excavating, Inc. is licensed with the North Carolina Licensing Board of General Contractors and is qualified to perform the scope of work for this project.



P.O. Box 200, West Jefferson, NC
 28694 548-2 Wade Bare Road, Jefferson,
 NC 28694 Phone: (336) 982-5550
 Fax: (336) 982-5200
PADCO@skybest.com

Watauga County
 Attn: Rex Buck
 Phone: (828) 264-5305
 Email: rex.buck@watgov.org
 Re: Watauga County Landfill Trailer Storage Area Improvements

Proposal Date: 09/19/2022 Job Title: Watauga County Landfill Trailer Storage Area Improvements – Boone, NC

PADCO Excavating, Inc. submits this proposal to complete the following work on the Watauga County Landfill Trailer Storage Area Improvements project for the Town of Boone, North Carolina.

Description	Amount
1. Mobilization & Project Management	\$12,118.00
2. Demo	\$10,066.26
3. Erosion Control	\$29,434.95
4. Grubbing/Stripping/Grading/Earthwork (Stone Base Not Included)	\$62,966.88
5. Asphalt Repair Over 18" Storm Drain Line	\$4,983.07
TOTAL BID:	\$119,569.16

ITEMS NOT INCLUDED: This price does not include the following items: Bonding, as-builts, testing/permitting, remedies for treatment, removal, and replacement of unsuitable soils, dewatering, drying, and chemical treatment of soils, solid rock removal, traffic control, relocation of existing utilities. The total bid amount also excludes all site concrete, concrete paving, and concrete stone base, asphalt paving (other than patch in description) asphalt paving stone base, storm drain pipe and structures. The total bid amount excludes any alternates. Padco Excavating, Inc. excludes any work not listed above. Any work completed that is not listed above will be charged based upon unit pricing.

NOTES:

- This quote is valid for 30 days from the date it is received.
- This proposal is based on civil plans only. Work deviating from these plans will be subject to price adjustment by a change order agreed upon by all parties.
- Due to the lack of a Geotechnical Exploration/Report, remediation of or removal and replacement of unsuitable soils, is not included in this proposal.
- Padco Excavating, Inc. is not responsible for protection of work against others. Request to fix work damaged by others will be billed to the owner.



P.O. Box 200, West Jefferson, NC
 28694 548-2 Wade Bare Road, Jefferson,
 NC 28694 Phone: (336) 982-5550
 Fax: (336) 982-5200
PADCO@skybest.com

Watauga County
 Attn: Rex Buck
 Phone: (828) 264-5305
 Email: rex.buck@watgov.org
 Re: Watauga County Landfill Trailer Storage Area Improvements

Proposal Date: 09/28/2022
 Job Title: Watauga County Landfill Trailer
 Storage Area Improvements – Boone, NC

PADCO Excavating, Inc. submits this proposal to complete the following work on the Watauga County Landfill Trailer Storage Area Improvements project for Watauga County, North Carolina.

Description	Amount
1. Storm Drain (6" PVC for Concrete Flume Not Included)	\$69,220.80
TOTAL BID:	\$69,220.80

ITEMS NOT INCLUDED: This price does not include the following items: Bonding, as-builts, testing/permitting, remedies for treatment, removal, and replacement of unsuitable soils, dewatering, drying, and chemical treatment of soils, solid rock removal, traffic control, relocation of existing utilities. The total bid amount also excludes all site concrete, concrete paving, and concrete stone base, asphalt paving (other than patch in description) asphalt paving stone base. The total bid amount excludes any alternates. Padco Excavating, Inc. excludes any work not listed above. Any work completed that is not listed above will be charged based upon unit pricing.

NOTES:

- **This quote is valid for 30 days from the date it is received.**
- **This proposal is based on civil plans only. Work deviating from these plans will be subject to price adjustment by a change order agreed upon by all parties.**
- **Due to the lack of a Geotechnical Exploration/Report, remediation of or removal and replacement of unsuitable soils, is not included in this proposal.**
- **Padco Excavating, Inc. is not responsible for protection of work against others. Request to fix work damaged by others will be billed to the owner.**

**CERTIFIED BID TABULATION
TRAILER STORAGE AREA IMPROVEMENTS
WATAUGA COUNTY**

ITEM	DESCRIPTION	QUANTITY	UNIT	Iron Mountain Construction Co., Inc. 601 Hospital Road Mountain City, Tennessee 37683		King General Contractors, Inc. Post Office Box 16278 Bristol, Virginia 24209	
				UNIT PRICE	TOTAL	UNIT PRICE	TOTAL
1	Mobilization & General Conditions	1	LS	\$17,000.00	\$17,000.00	\$98,125.55	\$98,125.55
2	Silt Fence	150	LF	\$12.50	\$1,875.00	\$17.95	\$2,692.50
3	Clearing and Grubbing	1	LS	\$12,500.00	\$12,500.00	\$20,233.09	\$20,233.09
4	Seeding, Fertilizing, and Mulching	1	LS	\$12,500.00	\$12,500.00	\$12,465.00	\$12,465.00
5	Erosion Control Matting	325	SY	\$12.00	\$3,900.00	\$13.91	\$4,520.75
6	Riprap w/ Filter Fabric	85	TON	\$156.00	\$13,260.00	\$194.76	\$16,554.60
7	Demolition	1	LS	\$12,500.00	\$12,500.00	\$18,812.30	\$18,812.30
8	Bollard	4	EA	\$2,500.00	\$10,000.00	\$2,295.48	\$9,181.92
9	6" Sch.40 Stormwater Pipe w/ cleanouts	125	LF	\$130.00	\$16,250.00	\$91.08	\$11,385.00
10	18" HDPE Pipe	152	LF	\$101.00	\$15,352.00	\$111.10	\$16,887.20
11	36" HDPE Pipe	216	LF	\$165.00	\$35,640.00	\$196.22	\$42,383.52
12	Junction Box	2	EA	\$4,125.00	\$8,250.00	\$5,849.08	\$11,698.16
13	Drop Inlet	1	EA	\$4,625.00	\$4,625.00	\$6,563.72	\$6,563.72
14	Concrete Landing Gear Pad, Wheel Pad, Curb Stop, Leachate Flume	1	LS	\$63,340.00	\$63,340.00	\$149,082.77	\$149,082.77
15	6" Conical Drain Plug	8	EA	\$2,256.00	\$18,048.00	\$533.17	\$4,265.36
16	CABC Stone	1,100	TON	\$48.00	\$52,800.00	\$52.75	\$58,025.00
17	2" I19b Asphalt Binder Course	210	TON	\$192.00	\$40,320.00	\$260.90	\$54,789.00
18	2" S9.5B Asphalt Surface Course	210	TON	\$192.00	\$40,320.00	\$260.90	\$54,789.00
19	Pavement Striping	1	LS	\$4,800.00	\$4,800.00	\$5,268.88	\$5,268.88
20	1" Muncipex Water line	250	LF	\$15.00	\$3,750.00	\$36.98	\$9,245.00
21	1" Ball Valve, Meter Box, tie into existing water service	1	EA	\$1,800.00	\$1,800.00	\$5,569.72	\$5,569.72
22	Yard Hydrant	1	EA	\$1,900.00	\$1,900.00	\$999.74	\$999.74
23	6" Sch.40 Sewer Line w/ cleanouts	350	LF	\$106.00	\$37,100.00	\$71.86	\$25,151.00
24	2500 Gallon Septic Tank	1	LS	\$24,633.00	\$24,633.00	\$46,874.39	\$46,874.39
25	Doghouse manhole	1	EA	\$7,020.00	\$7,020.00	\$12,466.08	\$12,466.08
26	Earthwork	1	LS	\$125,000.00	\$125,000.00	\$81,704.99	\$81,704.99
					\$584,483.00		\$779,734.24



This is to certify that the bids tabulated herein were publicly opened and read aloud at 2:00 p.m. on the 21st day of July 2022, in the Watauga County Sanitation Office, Boone, North Carolina and that said bids were accompanied by acceptable certified checks or bidder's bonds in the amount of 5% of the bid.

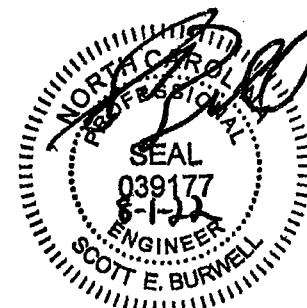

Structure : DI #1
Project : WATAUGA CO LANDFILL TRAILER AREA
 Project # : **22-9446**
 Customer : CRANBERRY WOOD WORKS (CWW)
 Structure Type : 2'X3' GRATE INLET
 Produced by : Mid-Atlantic Drainage, Inc.
 SC 843-358-4206 | NC 828-324-0808
 Entered By : jBogle
 Structure Status :

Top Elevation: **3230.20'**
 Design Height: 9.35'
 Provided Height: 9.35'
 Adjustment: **0.00"**
 Sump Height: **1.80"**
 Wall Thickness: 6"
 Floor Thickness: 6"
 Printed: 9/23/2022
 1:49:13 PM

Pipe #	Elevation (ft)	Wall Pipe Size/Type	Angle	Hole Up	Hole Height "	Hole Width "	Hole Type
(1)	3221.5	18 HDPE	90	0	24	24	HOLE

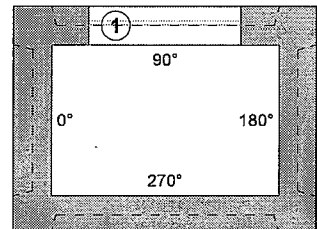
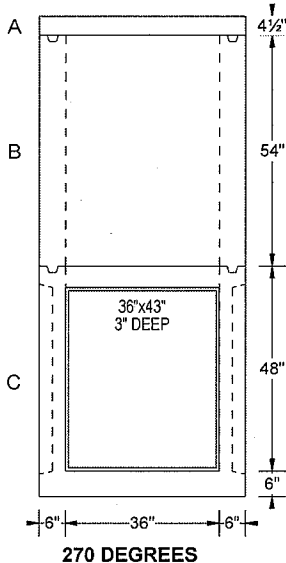
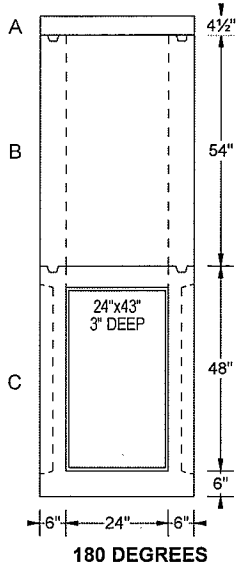
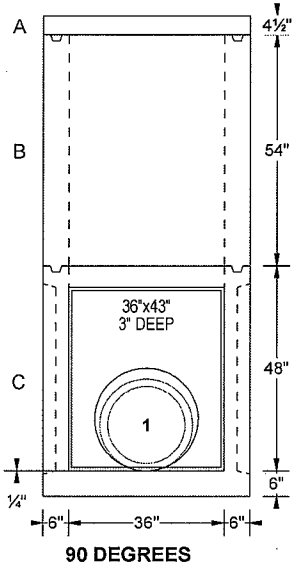
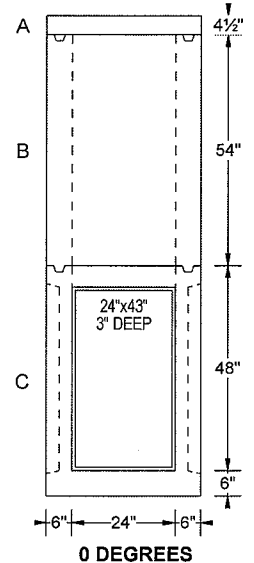

Ref	Description	Unit	Qty	Height (ft)	Weight (lbs)
A	2'X3'X4" NON-TRAFFIC FG NCDOT 840.16 (USF 4616-6221	EA	1	0.37	470
B	2'X3'X4.5' KO RISER	EA	1	4.5	3,042
C	2'X3'X4' SPECIAL KO BASE	EA	1	4	3,382
	CUSTOM OPENING	EA	1		
	Total Structure				6,894

Structure : JB #1
Project : WATAUGA CO LANDFILL TRAILER AREA
 Project # : **22-9446**
 Customer : CRANBERRY WOOD WORKS (CWW)
 Structure Type : 3'X3' JUNCTION BOX
 Produced by : Mid-Atlantic Drainage, Inc.
 SC 843-358-4206 | NC 828-324-0808
 Entered By : jBogle
 Structure Status :

Top Elevation: **3233.33'**
 Design Height: **4.98'**
 Provided Height: **4.98'**
 Adjustment: **0.00"**
 Sump Height: **1.80"**
 Wall Thickness: **6"**
 Floor Thickness: **6"**
 Printed: 9/23/2022
 1:49:15 PM

Pipe #	Elevation (ft)	Wall Pipe Size/Type	Angle	Hole Up	Hole Height "	Hole Width "	Hole Type
(1)	3229	18 HDPE	0	0	24	24	HOLE
(2)	3231.07	15 RCP	250	24.25	22	25.75	HOLE

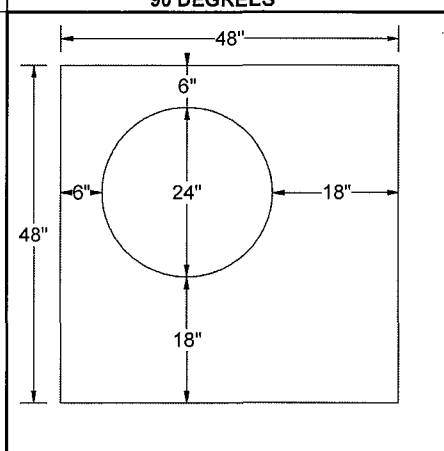
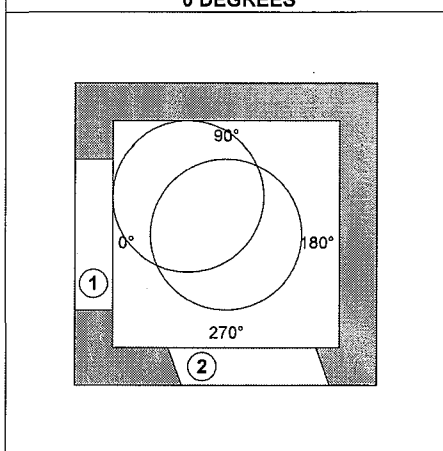
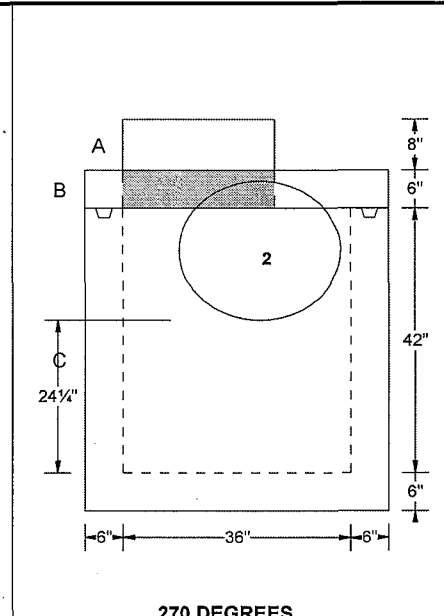
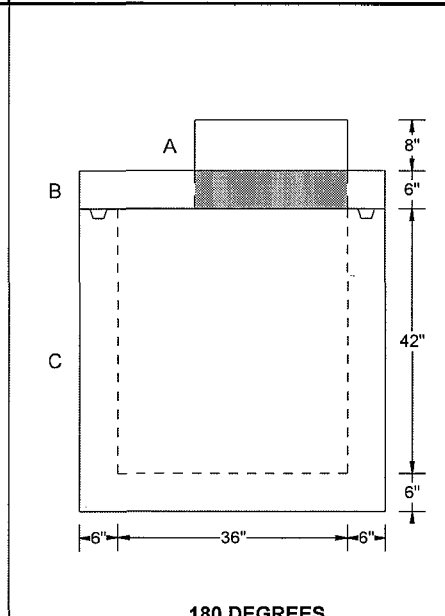
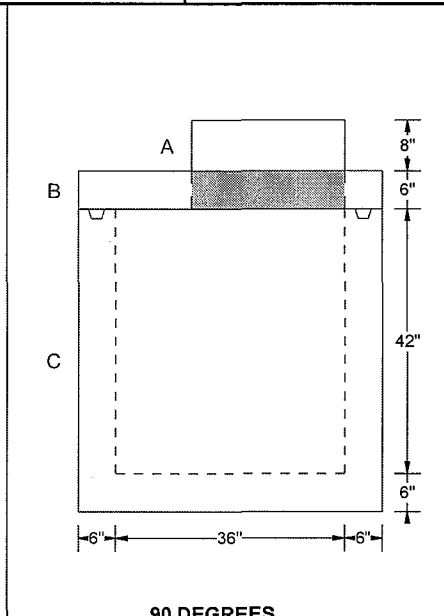
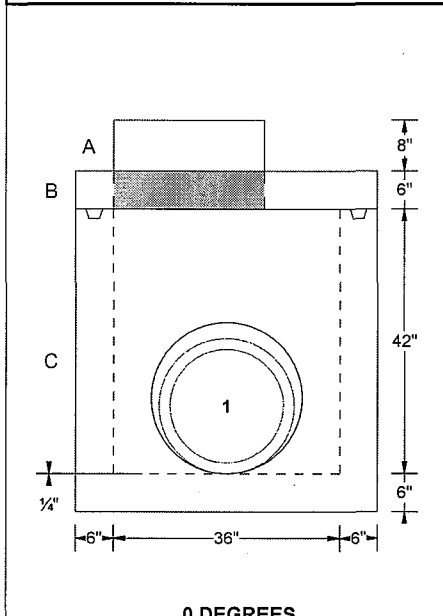

Ref	Description	Unit	Qty	Height (ft)	Weight (lbs)
A	24"X7.5" STORM RC TRAFFIC (USF 669 KL)	EA	1	0.67	315
B	4'X4'X6" TOP W/ 24" ROUND OFFSET HOLE	EA	1	0.5	964
C	3'X3'X3.5' SPECIAL SOLID BASE	EA	1	3.5	4,460
	CUSTOM OPENING	EA	2		
	Total Structure				5,739

Structure : JB #2
Project : WATAUGA CO LANDFILL TRAILER AREA
 Project # : 22-9446
 Customer : CRANBERRY WOOD WORKS (CWW)
 Structure Type : 48" STORM MANHOLE
 Produced by : Mid-Atlantic Drainage, Inc. | SC 843-358-4206 | NC 828-324-0808
 Entered By : jBogle

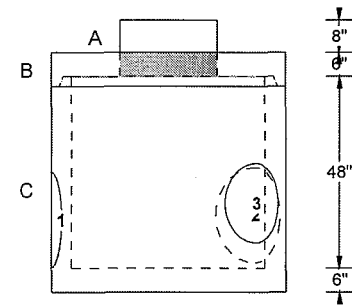
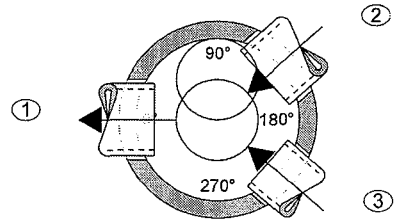
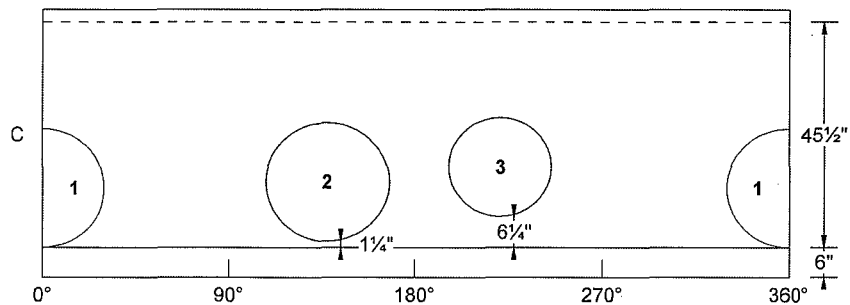

Top Elevation: **3232.50'**
 Design Height: 5.60'
 Provided Height: 5.60'
 Adjustment: **0.00"**
 Sump: **3.00"**
 Wall Thickness: 5"
 Floor Thickness: 6"
 Printed: 9/23/2022 1:49:16 PM

Ref	Description	Unit	Qty	Height (ft)	Weight (lbs)	Pipe #	Elevation (ft)	Pipe Size/Type	Angle	Hole Up (in)	Hole Size (in)	Hole/Type
A	24"X7.5" STORM RC TRAFFIC (USF 669 KL)	EA	1	0.67	315	(1)	3227.65	18 HDPE	0	0	24	HOLE
B	48" MH TOP W/ 24" OFFSET HOLE (58")	EA	1	0.70833	1,313	(2)	3227.75	18 HDPE	138	1.25	24	HOLE
C	48"X4' SPECIAL MH BASE	EA	1	3.79	4,305	(3)	3228.12	15 HDPE	221	6.25	20	HOLE
	CUSTOM OPENING	EA	3									
	Total Structure				5,933							

AGENDA ITEM 7:

EMERGENCY SERVICES MATTERS

A. Priority Dispatch License Renewal

MANAGER'S COMMENTS:

Mr. Will Holt, Emergency Services Director, will request the renewal of the Priority Dispatch software license for \$18,000. The software is used for processing of Fire, EMS and Law Enforcement calls with a nationally recognized list of questions that allow for standardization and prioritization of emergency calls. The cost of this software is 100% funded by 911 surcharge funds.

Board action is required to approve the contract with Priority Dispatch software license in the amount of \$18,000.



Watauga County Emergency Services

184 Hodges Gap Rd, Suite D
Boone, NC 28607
Phone 828-264-4235
Fax 828-265-7617



Fire Marshal ♦ Emergency Management ♦ Communications

September 23, 2022

To: Board of Commissioners

CC: Deron Geouque, County Manager
Samantha Jones, Finance Director
Anita Fogle, Clerk to the Board

Subject: Priority Dispatch License Renewal

Board of Commissioners,

Please consider my request for \$18,000 for the renewal of the Priority Dispatch software license. This suite of programs is used for call processing of Fire, EMS and Law Enforcement calls with a nationally recognized list of questions that allow for standardization and prioritization of emergency calls. It is also important to note that this set of questions is required by the State for medical emergencies, although the State does not require this specific vendor. This is a renewal of the current license in place and covers all three disciplines in the suite. The cost of this software is 100% funded by 911 surcharge funds.

Respectfully,

Will Holt
ES Director

AGENDA ITEM 7:

EMERGENCY SERVICES MATTERS

B. Rich Mountain Tower Renovation

MANAGER'S COMMENTS:

Mr. Holt will request Board approval to contract with Engineered Tower Solutions in the amount of \$32,600 to complete the necessary construction drawings and administrative filings for the renovation of the current Rich Mountain Public Safety Radio Tower. Adequate funds have been budgeted to cover the expense.

Board approval is required to contract with Engineered Tower Solutions in the amount of \$32,600 to complete the necessary construction drawings for the renovation of the current Rich Mountain Public Safety Radio Tower.



Watauga County Emergency Services

184 Hodges Gap Rd, Suite D
Boone, NC 28607
Phone 828-264-4235
Fax 828-265-7617



Fire Marshal ♦ Emergency Management ♦ Communications

September 23, 2022

To: Board of Commissioners

CC: Deron Geouque, County Manager
Samantha Jones, Finance Director
Anita Fogle, Clerk to the Board

Subject: Rich Mountain Tower Renovation

Board of Commissioners,

Please consider my request to have Engineered Tower Solutions complete the necessary construction drawings and administrative filings for the renovation of the current Rich Mountain Public Safety Radio Tower. This firm has been engaged throughout the process of our infrastructure project and is the State contracted engineering and construction firm for the VIPER radio system. Funds have been budgeted as part of the capital outlay for the upgrading of our public safety radio infrastructure.

Respectfully,

Will Holt
ES Director



Will Holt
 Emergency Services Director
Watauga County
 184 Hodges Gap Rd
 Boone, NC 28607

Subject: **Rich Mountain
 Engineering**

Mr. Holt:

ETS can perform the requested services for the following fees:

Item	Price	Scope
Existing Shelter Renovation CDs	\$5,500.00	Renovation and upfit drawings for existing shelter.
Partial Boundary Survey with 1A Certification	\$5,500.00	Includes topography.
NEPA	\$4,500.00	Complete environmental for the site.
Construction Staking	\$2,250.00	Per occurrence. Two are expected to be needed due to grading required on
FAA Filing	\$900.00	
FCC Filing	\$900.00	
National Public Notice	\$900.00	
Construction and Zoning Drawings (Tower and Compound)	\$3,750.00	
Geotechnical Investigation and Staking	\$7,500.00	
Lump Sum	\$32,600	

Please feel free to call or email with any questions or concerns. Thank you for the opportunity.

Best Regards,

J. Eric Dickerson, E.I., CWI, GC
 Vice President
Engineered Tower Solutions, PLLC
 919.280.4191 - Mobile
eric.dickerson@ets-pllc.com

Proposal Accepted by: _____ Date: _____

Blank Page

AGENDA ITEM 8:

HOWARD'S KNOB PARK MASTER PLAN AND ACCESSIBILITY FOR PARKS GRANT APPLICATION REQUESTS

MANAGER'S COMMENTS:

Mr. Eric Smallwood, Parks and Recreation Director, will request the Board approve the Howard's Knob Master Plan and apply for the Howard's Knob Park Accessibility for Parks grant application in the amount of \$350,000. The grant requires a 20% match which will be covered by the Watauga County TDA.

Board approval is required to approve the Howard's Knob Park Master Plan and apply for the Accessibility for Parks grant application in the amount of \$350,000.

Memo



To: Watauga County Board of Commissioners

From: Eric Smallwood, Parks and Recreation Director

cc: Deron Geouque, County Manager

Date: 9/28/2022

Re: Howard's Knob Park Masterplan and Grant

At September 28, 2022 special meeting of the Recreation Commission, there was not a quorum present. However, the members present unanimously supported approval of the updated Howard's Knob Park Master Plan to the Watauga County Board of Commissioners.

Staff recommends approval of the updated Howard's Knob Park Master Plan.

At the same meeting, the Recreation Commission members present unanimously supported approval of *Accessibility for Parks* grant for Howard's Knob Park in the amount of \$350,000.00 by the Watauga County Board of Commissioners

Staff recommends approval of the Howard's Knob Park *Accessibility for Parks* grant application in the amount of \$350,000.00

Accessibility for Parks (AFP) Grant Program: 2022 Basic Facts and Assurances

Local Government Name: _____	
Federal Employee I.D. Number: 56-_____ County: _____	
Local Government Contact Person for Grant* Name: <input type="checkbox"/> Mr. <input type="checkbox"/> Ms. _____ Title: _____ Organization: _____ Mailing Address: _____ City: _____ State: _____ Zip: _____ Telephone: _____ E-mail: _____ <small>*must be an employee of the sponsoring local government.</small>	Local Government Manager Name: <input type="checkbox"/> Mr. <input type="checkbox"/> Ms. _____ Title: _____ Organization: _____ Mailing Address: _____ City: _____ State: _____ Zip: _____ Telephone: _____ E-mail: _____
Chief Elected Official Name: <input type="checkbox"/> Mr. <input type="checkbox"/> Ms. _____ Title: _____ Mailing Address: _____ City: _____ State: _____ Zip: _____	Type of Project: <input type="checkbox"/> Primarily children with disabilities <input type="checkbox"/> Primarily Veterans with disabilities <input type="checkbox"/> Children with disabilities and veterans with disabilities Please use the "Description and Justification for this Project" to explain how the project will serve the intended groups.
Site Control (check all that apply): <input type="checkbox"/> Owned by local government. <input type="checkbox"/> Leased by the local government for 25 years or more <input type="checkbox"/> Easement <input type="checkbox"/> Owned by school board	Costs rounded to nearest dollar: AFP funds requested: \$ _____ .00 Local government's matching funds: \$ _____ .00 Total cost of project: \$ _____ .00
Recreation Resources Service (RRS) regional consultant: _____	
Project Name: _____	
Is this an LWCF-funded park on these lists of NC projects ? <input type="checkbox"/> yes <input type="checkbox"/> no	
If yes, list the grant number(s): _____	
Certification and Approval by Local Governing Board I hereby certify the information contained in the attached application is true and correct and the required one dollar of matching funds for five dollars of grant funds will be available within three years of submitting this application. This application has been approved by the local governing board.	
Chief Elected Official: _____ <div style="display: flex; justify-content: space-between; width: 100%;"> Print or Type Name Title Signature </div>	
If two local governments are applying together, this form must be completed and signed by each local government. One applicant must be identified by adding "primary sponsor" in the "Local Government Name" section.	
THIS FORM MUST BE COMPLETE IN ITS ENTIRETY FOR YOUR APPLICATION TO BE CONSIDERED	

Description and Justification for Howard Knob Park Local Government: Watauga County

Description:

The Town of Boone and surrounding area, including Appalachian State University have existed beneath the prominence of Howard Knob Mountain since the latter part of the 19th Century. More recently, during the energy crisis of the 1970s, the summit of Howard Knob was used by NASA as a test-site for the “world’s largest windmill.” The windmill has long-since been removed from service and dismantled, and the land was donated to the County in the 1980s for use as a public park. The latest iteration of the site will become even more inclusive, by providing new facilities designed to be accessed in meaningful and substantive ways by people of all abilities.

Howard Knob Park will become an important regional asset designed to attract visitors with physical and developmental challenges to the major renovations being planned for the existing park structures and additional new recreation facilities featuring amenities that incorporate the concepts of Universal Design. Development will include a compelling new overlook and viewing platform, nature trails with accessible paved paths, signage for the visually impaired, a picnic shelter and pavilion retrofitted with ADA furnishings, a tranquility garden, and expanded vehicle parking, including five new ADA spaces. Howard Knob Park is located 4,420 feet above sea level on approximately 5.7 acres of public land and will serve as a significant recreational and community asset in the heart of the High Country. The park will be an anchor point for recreation in Watauga County as it will provide connectivity and become an important regional node of the Northern Peaks State Trail (NPST), which is planned to stretch 40 miles and connect several dramatic mountain landscapes in the area. The NPST at Howard Knob Park is unique in that it will allow those with physical and developmental disabilities to have better access to this state trail, if only for a short distance, yet still experience its many physical and mental health benefits.

This project will provide users with enriching and edifying experiences in a natural and awe-inspiring environment. It will offer visitors long-range mountain views and a unique perspective of Boone from 1000 feet above downtown. Signs for the visually impaired will help achieve the goal of improved accessibility. The amenities included in this park will provide all users with the restorative effects nature provides by virtue of a unique tranquility garden designed to offer autistic children and their families, or perhaps service members recovering from PTSD, with a calm and quiet space for reflection and healing in an enjoyable and peaceful outdoor setting.

Justification:

The Howard Knob Park project will provide excellent recreation opportunities and fill an important need for parks and open space specifically designed to cater to children and veterans with physical or mental disabilities. According to the Veterans Service Office of Watauga County, in 2021 there were 2,952 veterans residing in the County. It is estimated that 46% of veterans here are between the ages of 18-34, and more than 13% have some type of disability. The Exceptional Children Program for Watauga County Schools indicates that there are 961 students in their system with some type of diagnosed disability, varying from very significantly involved to mild disabilities, with the most common categories being: autism, learning disabled, and speech impaired. There are very limited public facilities designed to serve their specific recreational needs (one area elementary school).

Watauga County is partnering with the Watauga County Tourism Development Authority (WCTDA), to protect the natural environment while providing a unique recreational facility for these vulnerable populations. The WCTDA and Watauga County are leading the efforts to implement the Howard Knob Park Master Plan to create a public space with amenities that will greatly benefit all visitors, especially those with prevalent physical and developmental disabilities. The WCTDA will be investing well over the dollar-for-dollar local funding match requirement (the local match is currently estimated to be \$1,083,000). The Universal Design standards included in the overlook and viewing area of the Howard Knob Park project will be paramount to the spirit of this endeavor.

The renovated Howard Knob Park will help the Town of Boone and Watauga County realize their vision of providing more recreation facilities that are accessible to all people, regardless of physical or developmental abilities. These new improvements will offer a unique experience not available in the typical public park setting. Safe and accessible access to the park and the surrounding natural environment will not only expand recreational opportunities for residents but provide a much-needed asset for the area. This project will contribute to the well-being of both children and veterans with mental and physical challenges and comply with the Americans with Disabilities Act and Accessibility Guidelines (ADAAG).

Project Costs
Howard Knob Park – Watauga County
September 2022

Project Elements (Include specific units - sizes, numbers, lengths, etc. - for each item.)	Unit	Unit Cost	Total Item Cost
Building Costs			
ADA Overlook/ Viewing Platform	Lump Sum	\$800,000	\$800,000
Renovated Picnic Shelter	Lump Sum	\$50,000	\$50,000
Tranquility Garden	Lump Sum	\$90,000	\$90,000
ADA accessible paths	1300 linear ft.	\$160/linear foot	\$208,000
Signage	Lump Sum	\$30,000	\$30,000
Site furnishings and landscaping	Lump Sum	\$60,000	\$60,000
Expanded Parking (Including ADA)	1000 linear feet	\$80 / linear foot	\$80,000
Site preparation	Lump Sum	\$85,000	\$85,000
Cost to Build or Renovate			\$1,403,000
Contingency for the Cost of Building / Renovating			
Contingency (not to exceed \$30,000)	5%		\$30,000
Planning and Incidental Land Acquisition Costs			
Construction management, site planning, preliminary design, survey and appraisals, or the cost of preparing the application (not to exceed 20% of the cost of the project)	N/A		\$0
Total Project Cost			\$1,433,000
Total AFP Grant Request			\$350,000
Total Local Match			\$1,083,000

Howard Knob Park

Watauga County, NC

AFP Site Plan Map

Map Produced: 12 September 2022

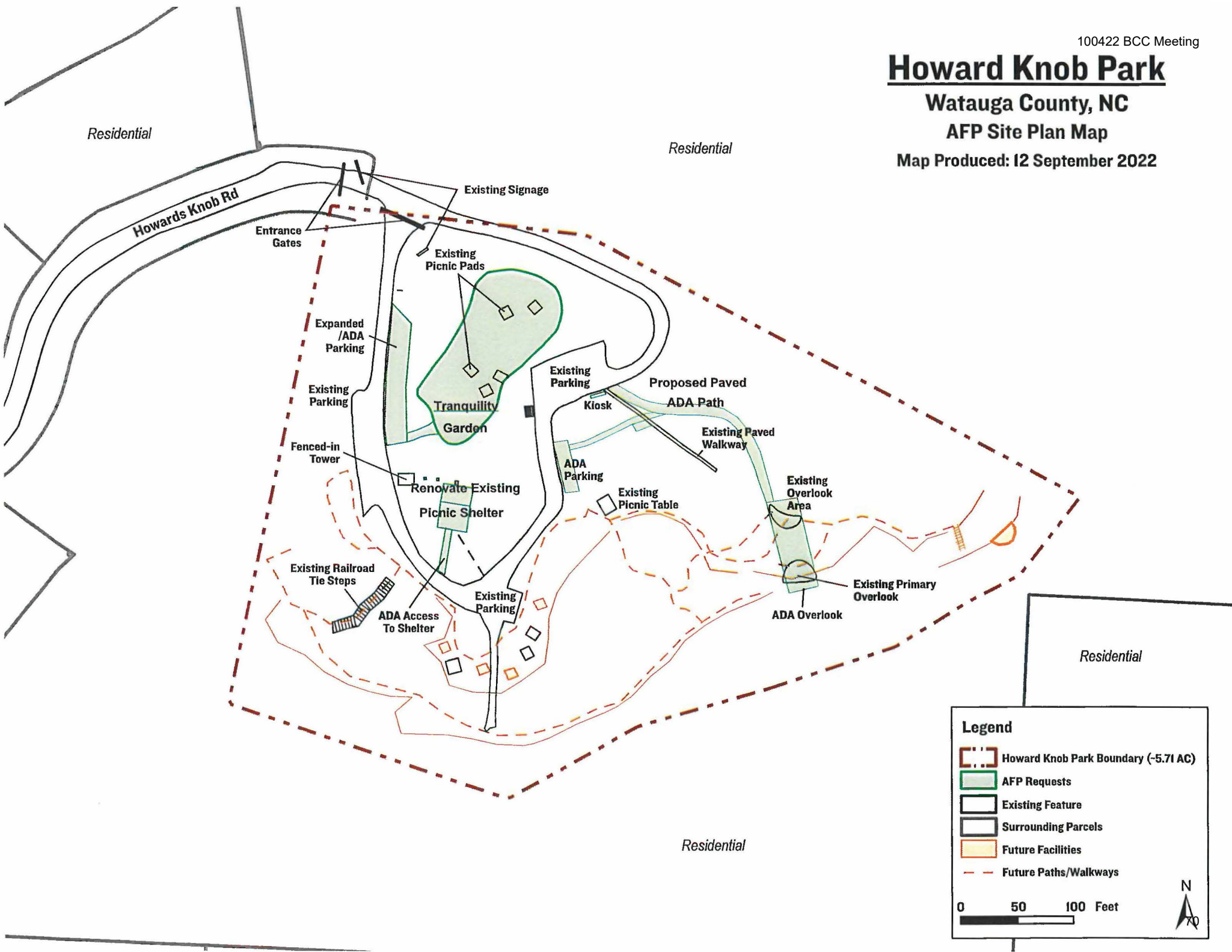

Legend

- Howard Knob Park Boundary (~5.71 AC)
- AFP Requests
- Existing Feature
- Surrounding Parcels
- Future Facilities
- Future Paths/Walkways

0 50 100 Feet

N

AGENDA ITEM 8:**MISCELLANEOUS ADMINISTRATIVE MATTERS*****A. Valle Crucis Elementary School Project Bid Award*****MANAGER'S COMMENTS:**

Bids were solicited for the new Valle Crucis Elementary School and were due September 1, 2022. Three bids were received with H&M Constructors being the lowest responsive bidder with the County exercising all of the bid alternates. The County will be informed of the LGC's approval of the project prior to the meeting. Adequate funds are available in the County's CIP to cover the debt service of the project.

Board approval is required to accept the bid from H&M Constructors in the amount of \$47,874,600 and the total project budget of \$53,530,000 which includes technology, architect fees, contingencies, and FF&E.



September 29, 2022

Watauga County Manager
814 West King Street
Suite 205
Boone, NC 28607

Attn: Mr. Deron Geouque
County Manager

RE: VALLE CRUCIS ELEMENTARY SCHOOL- AWARD NOTIFICATION

Dear Mr. Geouque,

Please see attached certified bid tab and documentation of bids received on September 1, 2022.

The Base bid and selected alternates make HM Constructors the lowest responsive, responsible bidder with a total of is \$47,874,600. We have discussed and reviewed the bids with the contractor and recommend moving forward with the award of the contract. If you have any additional questions, please let me know.

Sincerely,
CLARK NEXSEN

Chadwick S Roberson, AIA, LEED AP BD+C
Principal



301 College Street, Suite 300
Asheville, NC 28801
P: 828.232.0608 | F: 828.232.1606
clarknexsen.com

CLARK NEXSEN

BID TABULATION -SINGLE PRIME

Project:Valle Crucis School
 Owner: Watauga County
 Project #: CN 9390

CLARKNEXSEN
 Date of Bids: September 1, 2022
 Time of Bids: 3:00pm

BID ITEMS						
Ref #	Bid Item #	Item Description				
		Name of Bidder	Hickory-Construction	Muter Construction	H&M Constructors ***	Edison Foard, Inc.
		License #	1145	73095	1245	NO BID
		Base Bid	\$ 47,300,000.00	\$ 49,808,000.00	\$ 47,600,000.00	
		Alternate No. 1: Wall Type W01.8W in lieu of Wall Type W01.8 where indicated on drawings	\$ 380,000.00	\$ 439,000.00	\$ 101,000.00	
		Alternate No. 2: Wall Type W02.6W in lieu of Wall Type W02.6 where indicated on drawings	\$ 42,000.00	\$ 45,000.00	\$ 24,400.00	
		Alternate No. 3: Wall Type W02.8W in lieu of Wall Type W02.8 where indicated on drawings	\$ 16,800.00	\$ 170,000.00	\$ 109,000.00	
		Alternate No. 4: Corridor 101A Vertical Acoustic Baffles in addition to Acoustical Gypsum Board	\$ 26,800.00	\$ 41,000.00	\$ 40,200.00	
		Alternate No. 5: Owner Preferred Building Control	No Change	\$ 61,000.00	No Change	
		Alternate No. 6: Owner Preferred Fire Alarm Control System	No Change	\$ 10,000.00	No Change	
		Alternate No. 7: Owner Preferred Door Hardware	No Change	\$ 25,000.00	No Change	
		Alternate No. 8 Owner Preferred Roof Paver and Extensive Green Roof System R02	\$ 500,000.00	\$ 426,000.00	No Change	
		Alternate No. 9: Roof Type R01G in lieu of R01	\$ 500,000.00	\$ 80,000.00	No Change	
		TOTAL COMBINED BID	\$ 48,765,600.00	\$ 51,105,000.00	\$ 47,874,600.00	\$ 0.00
Unit Price Work						
	UP1	Rock Excavation (Trench)	\$450.00	\$ 290.00	\$ 350.00	\$
	UP2	Rock Excavation (Mass)	\$300.00	\$ 48.00	\$ 200.00	\$
	UP3	Unsuitable Soils Excavation	\$20.00	\$ 9.50	\$ 20.00	\$
	UP4	Replacement of rock excavation or unsuitable soils with No. 57 washed stone	\$70.00	\$ 13.00	\$ 50.00	\$
	UP5	Replacement of rock excavation or unsuitable soils with compacted soil	\$35.00	\$ 58.00	\$ 30.00	\$
	UP6	One ton of CABC stone	\$40.00	\$ 65.00	\$ 35.00	\$
	UP7	One ton of Class 2 Rip Rap	\$90.00	\$ 68.00	\$ 50.00	\$
	UP8	One ton of No. 57 stone	\$50.00	\$ 65.00	\$ 45.00	\$
	UP9	One square yd of Mirafi HP 370	\$10.00	\$ 7.00	\$ 10.00	\$
	UP10	Ten Linear feet of 6" perforated PVC pipe	\$800	\$ 22.00	\$ 250.00	
	UP11	3'-0" x 7'-0" Door	\$2,000	\$ 3000.00	\$ 4000.00	
	UP12	Add/delete exit sign	\$800	\$ 700.00	\$ 800.00	
	UP13	Fire alarm device	\$1,100	\$ 1000.00	\$ 1100.00	
	UP14	Fire alarm pull station	\$900	\$ 875.00	\$ 900.00	
	UP15	Add/delete smoke detector	\$1,100	\$ 915.00	\$ 1100.00	
	UP16	Add/delete 120v rec.	\$500	\$ 500.00	\$ 500.00	\$
Subcontractor listing						
	HVAC		Associated Heating and Air	Associated Heating and Air	Gentry Services	
	Plumb		Bolton	Bolton	Bolton	
	Elec		Fountain Electric	Fountain Electric	Lake Electric	
	Gen		Hickory Construction	Muter Construction	H&M Constructors	
ABI Forms						
		Affidavit A	Yes	Yes	Yes	
		Affidavit B	Yes	Yes	Yes	
		Bid bond	Yes	Yes	Yes	
		Addendum #1-2 , Clarification #1-2 noted	Yes	Yes	Yes	

*** Apparent low bidder

Certified as Read:

Chadwick S Roberson, AIA LEED AP BD+C

Date 09/01/2022

Blank Page

AGENDA ITEM 9:

MISCELLANEOUS ADMINISTRATIVE MATTERS

B. Announcements

MANAGER’S COMMENTS:

Please save the date of October 6, 2022, at 2:00 P.M. for a meeting with the Board of Commissioners as well as BREMCO and Skyline representatives to view the progress to expand critical broadband service availability to the majority of homes in the County. The meeting has been set for 2:00 P.M. at 131 Foggy Ridge Road off of Ben Miller Road in Deep Gap.

Save the Date of Tuesday, December 13, 2022, from 11:30 A.M. to 2:00 P.M. for the Annual Employee Christmas Lunch at Dan’l Boone Inn.

AGENDA ITEM 10:

PUBLIC COMMENT

AGENDA ITEM 11:

BREAK

AGENDA ITEM 12:

CLOSED SESSION

Attorney/Client Matters – G. S. 143-318.11(a)(3)